

**8.0 A Single-Phase Silicon Bridge Rectifier**  
Rectifier Reverse Voltage 50 to 1000V



**Features**

- This series is UL listed under the Recognized Component Index
- Single In-Line terminals array suitable for P.C. board mounting
- Surge overload ratings to 300 amperes peak
- The plastic material used carries Underwriters Laboratory flammability recognition 94V-0
- High temperature soldering guaranteed 265°C/10 seconds/.375"(9.5mm) lead length at 5 lbs (2.3kg) tension

**Mechanical Data**

Case: Molded plastic  
 Terminals: Plated wire leads solderable per MIL-STD-202, Method 208  
 Mounting Position: Any  
 Mounting Torque: 5 in-lb maximum  
 Weight: 0.3 ounce, 8 grams (approx)

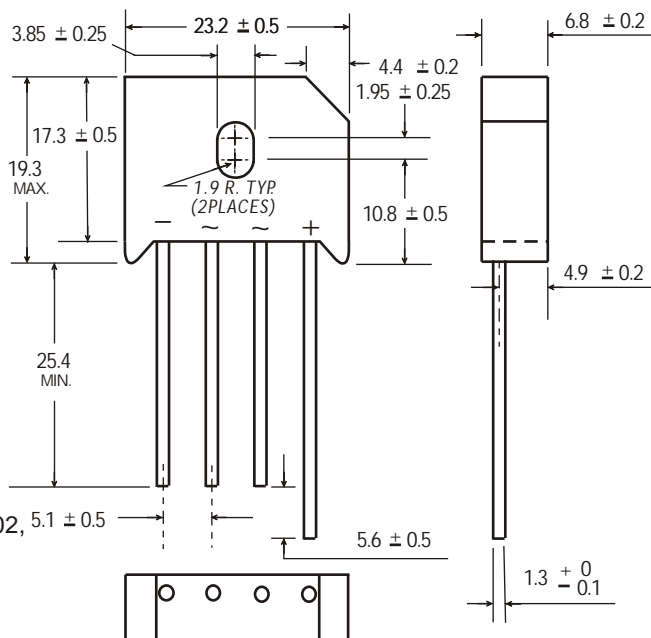

Dimensions in millimeters(1mm =0.0394")

**Maximum Ratings & Thermal Characteristics**

Rating at 25°C ambient temperature unless otherwise specified, Resistive or Inductive load, 60 Hz.  
 For Capacitive load derate current by 20%.

Parameter	Symbol	RS801	RS802	RS803	RS804	RS805	RS806	RS807	unit
Maximum repetitive peak reverse voltage	VRRM	50	100	200	400	600	800	1000	V
Maximum RMS bridge input voltage	VRMS	35	70	140	280	420	560	700	V
Maximum DC blocking voltage	VDC	50	100	200	400	600	800	1000	V
Maximum average forward rectified output current at T <sub>C</sub> =100°C T <sub>C</sub> =45°C	IF(AV)	8.0 6.0							A
Peak forward surge current single sine-wave superimposed on rated load (JEDEC Method)	IFSM	300							A
Rating for fusing ( t<8.3ms)	I <sup>2</sup> t	373							A <sup>2</sup> sec
Typical thermal resistance per element (1)	ReJA	2.5							°C / W
Operating junction and storage temperature range	T <sub>J</sub> , T <sub>STG</sub>	-55 to + 150							°C

**Electrical Characteristics**

Rating at 25°C ambient temperature unless otherwise specified. Resistive or Inductive load, 60Hz.  
 For Capacitive load derate by 20 %.

Parameter	Symbol	RS801	RS802	RS803	RS804	RS805	RS806	RS807	Unit
Maximum instantaneous forward voltage drop per leg at 8.0A	V <sub>F</sub>	1.1							V
Maximum DC reverse current at rated DC blocking voltage per element T <sub>A</sub> =25°C T <sub>A</sub> =125°C	I <sub>R</sub>	10 1000							μA

**Notes:** (1)Thermal resistance from Junction to Ambient on P.C.board mounting.

**Rating and Characteristic Curves ( TA=25°C Unless otherwise noted )  
RS801 thru RS807**

**Fig. 1 Derating Curve for Output Rectified Current**

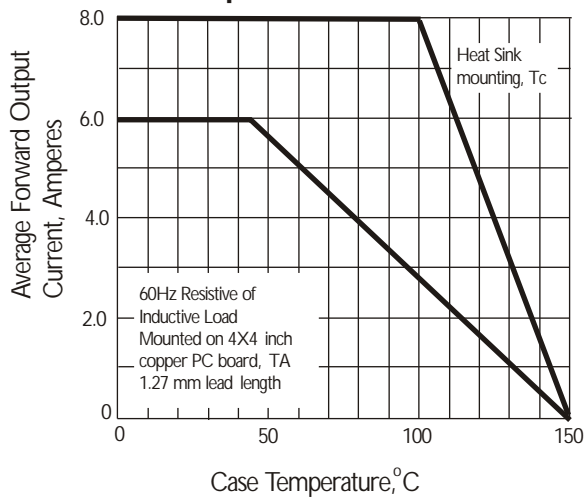

**Fig. 2 Maximum Non-repetitive Peak Forward Surge Current**

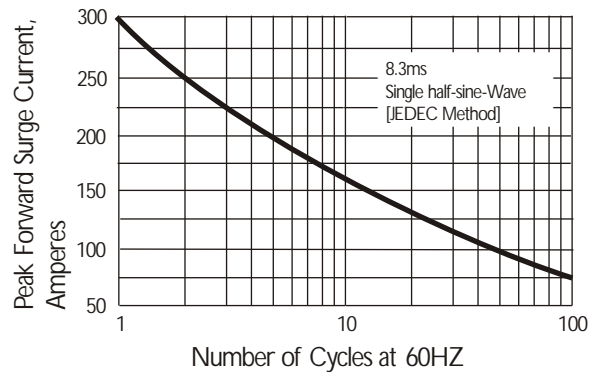

**Fig. 3 Typical Instantaneous Forward Characteristics**

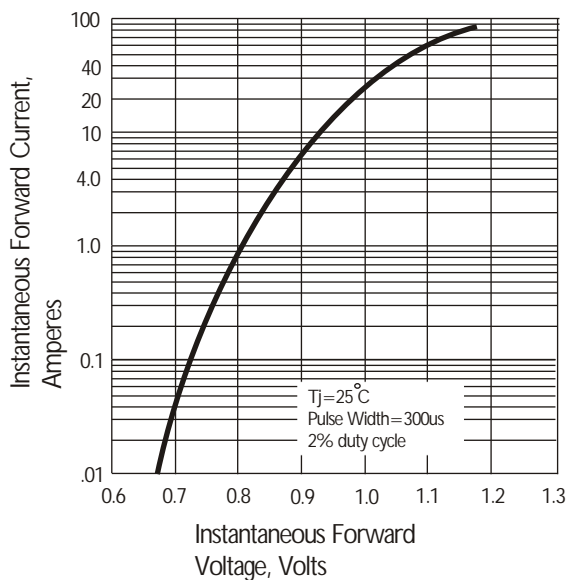

**Fig. 4 Typical Reverse Characteristics**

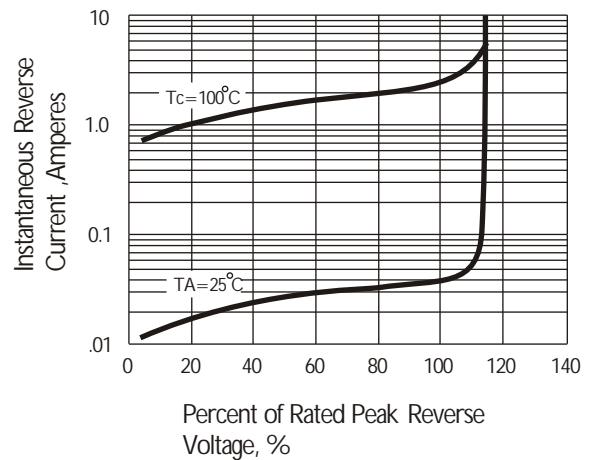

**Fig. 5 Typical Junction Capacitance**

